

# DATA SHEET

## Wireless Extender for HDMI, Keyboard and Mouse 25-0230 - HDWX-100-TR

### Contents

- ◆ Description
- ◆ Features
- ◆ Applications
- ◆ Technical Specification
- ◆ Connection Diagram
- ◆ Block Diagram
- ◆ Drawing
- ◆ Troubleshooting

#### OPTICIS HQ

Opticis Co., Ltd.  
# 16Fl, Kins Tower Jeongja 331,  
8 Sungnam-daero, Bundang-gu  
Sungnam-si, Gyunggi-do, 463-782  
South Korea  
Te l: +82 (31) 719-8033  
Fax: +82 (31) 719-8032  
[www.opticis.com](http://www.opticis.com)  
tosales@opticis.com

Direktronik AB  
Konsul Johnsons väg 15  
SE-149 45 Nynäshamn  
Sweden  
Te l: +46 8 524 00 700  
[www.direktronik.se](http://www.direktronik.se)  
info@direktronik.se

## Wireless Extender for HDMI, Keyboard and Mouse, HAFX-100-TR

### 1. Description

The OPTICIS wireless Extender, HDWX-100-TR is designed for wireless signals extending of HDMI, keyboard and mouse. The transmitter module HDWX-100-T connected to the HDMI source encodes the HDMI by H.264 and transmits the signal via advanced Wi-Fi, 802.11n technology. The receiver module, HDWX-100-R connected to the display receives and decodes wireless signal into HDMI for display. The USB keyboard and mouse interface in the receiver module, HDWX-100-R also can be accessed to the source via transmitter module HDWX-100-T, if it is connected to the source by USB interface.

The HDWX-100-TR supports the digital video data of full HD up to 1920x1080p at 60Hz and 7.1ch surround audio and transmits the signal up to 30 meters (100feet). It also enables to distribute one (1) video source up to four (4) displays and makes four (4) local keyboard and mouse accesses to the source.

By using GUI interface, user can select one of active transmitters for pairing in the receiver side. With these key features, 4 x 4 wireless routing system can be configured without any electrical connection.

### 2. Features

- Compact design for direct hook up
- Wi-Fi standard: 802.11n, 5GHz, 2x2 MIMO, two internal antennas
- Maximum throughput: 300Mbps
- WPA/WPA2 and QoS
- Video resolution: Up to 1920x1080 at 60Hz
- Audio: 7.1ch surround
- HDMI V1.3 and HDCP2.0
- DVI V1.0 backward compatibility
- USB backchannel: extend PC control in remote-site (RX): HID mouse and keyboard
- Provides LED indicators for Power and Status (wireless connection) in Transmitter and Receiver.
- Size (WDH): 66 x 105 x 25mm

### 3. Applications

- Home AV
- KVM
- Video control room
- Digital signage
- Medical imaging

### 4. Technical Specifications

#### 4.1 General Specifications

<b>Wi-Fi</b>	
Wi-Fi standard	802.11n, 5GHz, 2T2R MIMO
Security	WPA/WPA2
QoS	802.11e QoS WMM/WMM-PS
Band	5GHz
Mode	40MHz
Frequency	5.17~5.835GHz
Tx Power	Typical 13dBm at 5GHz(TBD)
Coverage distance (In case of 1:1 connection)	- LOS (Line of Sight): Up to 80meters - NLOS: Up to 30meters (Typically 20meters, Indoor)
Maximum throughput	Up to 300Mbps
Antenna	Two internal antennas
<b>Transmitter Only</b>	
Compression (Encoding)	H.264/MPEG4 AVC(part 10)
Video Input	HDMI Rx 1.3
Operation	WPS: PBC and PIN
<b>Receiver Only</b>	
Compression (Decoding)	H.264/MPEG4 AVC(part 10)
Video output	HDMI Tx 1.3, DVI 1.0 backward compatibility
Operation	Connection manager (GUI), EDID
<b>CODEC</b>	
Resolution	Up to 1080p (1920 x1080), 60Hz
Video format	RGB 4:4:4, YCbCr4:4:4, YCbCr4:2:2
Audio format	4 x I <sup>2</sup> S, 7.1ch surround audio
HDCP	HDCP2.0
video latency	CODEC: Sub 1msec
<b>General</b>	
Multi-cast	1 transmitter to 4 receivers distribution at 1080p, 60Hz
Connectivity	P2P (Peer to Peer) with Wi-Fi Direct 5GHz
P2P connection	Wi-Fi Protected Setup(WPS): PBC and PIN
Input/Output interface	HDMI Tx/Rx (Audio/Video), USB for FW Upgrading
USB KVM extender	USB Mouse & Keyboard on the remote site
Reset button	Reset to factory defaults
LEDs	2 LEDs: Power/Connectivity Status
Dimension (WDH)	105 x 66 x 25mm
Certifications	CE/FCC/RoHs

## 4.2 Electrical Characteristics

	Parameter	Symbol	Minimum	Typical	Maximum	Units	
Power Supply	Supply Voltage, Temp 25°C	VCC	+ 4.75	+ 5.0	+ 5.25	V	
	Supply Current	Tx	ITCC	-	2	-	A
		Rx	IRCC	-	2	-	A
	Power Dissipation	Tx	PTX	5.5	6.5	7.5	W
Rx		PRx	5	6	7	W	
TMDS	Data Output Load	RLD		50		Ω	
	Graphic Supply Voltage	GVCC	+ 3.15	+ 3.3	+ 3.45	V	
	Single-Ended High Level Input Voltage	GVIH	GVCC - 0.01	GVCC	GVCC + 0.01	V	
	Single-Ended Low Level Input Voltage	GVIL	GVCC - 0.6	-	GVCC - 0.4	V	
	Single-Ended Input Swing Voltage	GVISWING	0.2	-	0.75	V	
Wi-Fi Link	Maximum Bit rate			300		Mbps	
	Tx Output Power	PT	3.5	13.5	+16.5	dBm	
	Receiver Input	PR		-70		dBm	

(T<sub>A</sub> = 0 °C to +50 °C, unless otherwise noted)

## 4.3 LED Indicators

LED	Power Status LED	Wireless Status LED
Off	Power Off	-
Blinking	Boot-up procedure & Factory Reset	Connection trial
On (Blue)	Power On	Connection completed

## 4.4 HDMI Pin Description

Pin	Symbol	Functional Description
1	CH2+	TMDS Data Signal Channel 2 Positive
2	GND	TMDS Data Signal Channel 2 Shield
3	Ch2-	TMDS Data Signal Channel 2 Negative
4	CH1+	TMDS Data Signal Channel 1 Positive
5	GND	TMDS Data Signal Channel 1 Shield
6	CH1-	TMDS Data Signal Channel 1 Negative
7	CH0+	TMDS Data Signal Channel 0 Positive
8	GND	TMDS Data Signal Channel 0 Shield
9	CH0-	TMDS Data Signal Channel 0 Negative
10	CLK+	TMDS Clock Channel Positive
11	GND	TMDS Clock Signal Shield
12	CLK-	TMDS Clock Channel Negative

13	CEC	Consumer Electronics Control
14	Reserved	Not used
15	SCL	HDCP/DDC communication clock
16	SDA	HDCP/DDC communication data
17	GND	DDC/CEC shield
18	5V	5 V Input for Transmitter from Host
		5 V Output for Monitor from Receiver
19	Hot plug Detect	Signal is driven by monitor to enable the system to identify the presence of a monitor

#### 4.5 Absolute Maximum Ratings

Parameter	Symbol	Minimum	Maximum	Units
Supply Adaptor Voltage, Temp=25°C	VCC	-0.3	+5.25	V
Operating Temperature	Top	-10	60	°C
Operating Relative Humidity	RHop	5	80*	%RH
Storage Temperature	Tsto	- 20	+ 75	°C
Storage Relative Humidity	RHsto	5	95*	%RH

#### 4.6 Recommended Operating Conditions

Parameter	Symbol	Minimum	Typical	Maximum	Units
Ambient Operating Temperature	TA	0		+ 50	°C
Data Output Load (HDMI)	RLD		50		Ω
Power Supply Rejection (Note1)	PSR		100		mVp-p
Supply Voltage	VCC	+ 4.75	+ 5.0	+ 5.25	V

#### 4.7 Environment Tests

Heading	Test	Conditions	Duration	Sample Size	Remarks
Operating Test	Operating at each Temperature (See Note)	-10~60°C (Interval: 10°C)	2 HR (Each Temperature)	n=3	1. TS: Storage Temperature 2. RH: Relative Humidity
Storage Test	Low Temperature	TS = -20°C	128 HR	n=3	
	High Temperature	TS = 60°C	128 HR	n=3	
	High Humidity / High Temperature	TS: 65°C RH: 85%	128 HR	n=3	
Mechanical Test	Mechanical Shock	Pulse: 11 ms Peak level: 30 g Shock pulse: 6times/Axis	-	n=3	
	Mechanical Vibration	Peak acceleration: 5 g Frequency: 10~55Hz Sweep time: 5 Minutes 2 Times/Axis	-	n=3	

#### 4.8 EMC Test



- EMI: Meet FCC class A or B (ICES-003) and CE class A or B

STANDARDS		CONDITIONS
EN 55 022 (CISPR22) FCC; PART 15 SUBPART B	CE (Conducted Emission) & RE (Radiated Emission)	Meet Class A or B
EN 61000-3-2 (IEC 61000-3-2)	Harmonics	Meet Class A or B
EN 61000-3-3 (IEC 61000-3-3)	Flickers	Meet Class A or B

- EMS: Meet CE standards (EN 55024) and CISPR24 equivalents

STANDARDS		CONDITIONS
EN 61 000-4-2:1995	Electrostatic Discharge Immunity (Air: 8kv, Contact: 4kv)	Meet Criterion A or B
EN 61 000-4-3:1996	Radiated RF E-Field (80~1000 MHz) 3V/m (AM 80%, 1kHz)	Meet Criterion A or B
EN 61 000-4-4:1995	Fast Transients (5kHz, 60Seconds)	Meet Criterion A or B
EN 61 000-4-5:1995	Surge Transients	Meet Criterion A or B
EN 61 000-4-6:1996	Conducted Susceptibility (CS) Radiated Susceptibility (RS)	Meet Criterion A or B
EN 61 000-4-11:1994	Voltage Dips, Interruption & Variation	Meet Criterion A or B, and C

#### 4.9 Supporting Resolutions

- 480i60, 576i50
- 480p60, 576p50
- 720p50, 720p60
- 1080i30, 1080i50, 1080i60
- 1080p24, 1080p30, 1080p50, 1080p60
- 640x480p60
- 800x600p60
- 1024x768p60
- 1280x768p60
- 1280x960p60
- 1280x1024p60
- 1600x1200p60
- 1920x1080p60

Note: Some DVI resolutions may not be shown properly on the display. The image would be shifted to one side.

#### 4.10 5GHz Wi-Fi Channels

Because of wireless signal regulations, HDWX-100-TR is managed by two different firmwares according to the shipment locations (US version and Europe version).

- US Version: US, Korea and others.
- Europe Version: Europe, Japan, and others.

Band	Available Channels				DFS (US &Japan)
	US	Europe	JAPAN	Korea	
Band A (5150~5250)	36,40,44,48	36,40,44,48	36,40,44,48	36,40,44,48	
Band B (5250~5725)	52,56,60,64,100, 104,108,112,116 ,132,136	52,56,60,64,100, 104,108,112,116 ,120,124,128,132 ,136	52,56,60,64,100, 104,108,112,116 ,120,124,128,13 2,136	52,56,60,64,100, 104,108,112,116 ,120,128	52,56,60,64,100,104,108 ,112,116,132,136
Band C (5725~5875)	149,153,157,161	NA		149,153,157,161	

### 5. Connection Diagram



User can configure transmitter and receiver in two ways.

- 1:1 Cast: Videos stream from 1 transmitter to 1 receiver.
- 1:4 Multi-cast: Videos stream from 1 transmitter to 4 receivers.

Note: Multi-cast may cause 1) reduction of transmitting distance, 2) degradation of image quality  
3) screen refresh when additional joins happen.

6. Block Diagram

Transmitter, HDWX-100Tx

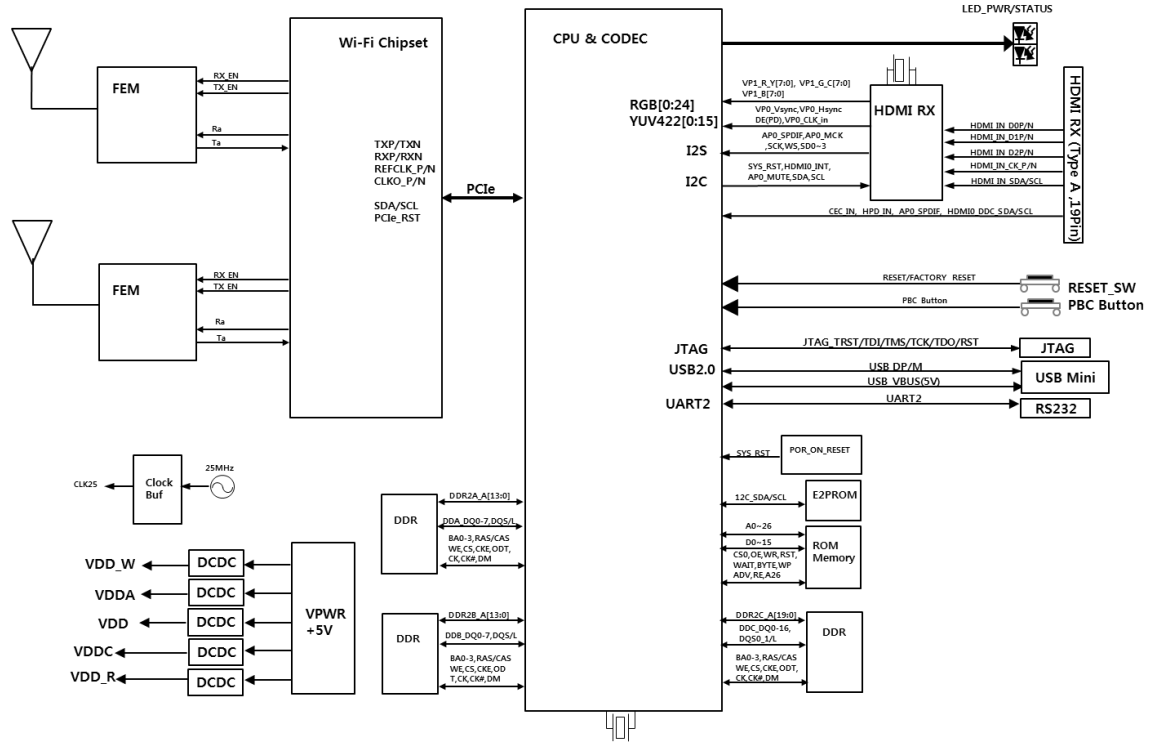

Receiver, HDWX-100Rx

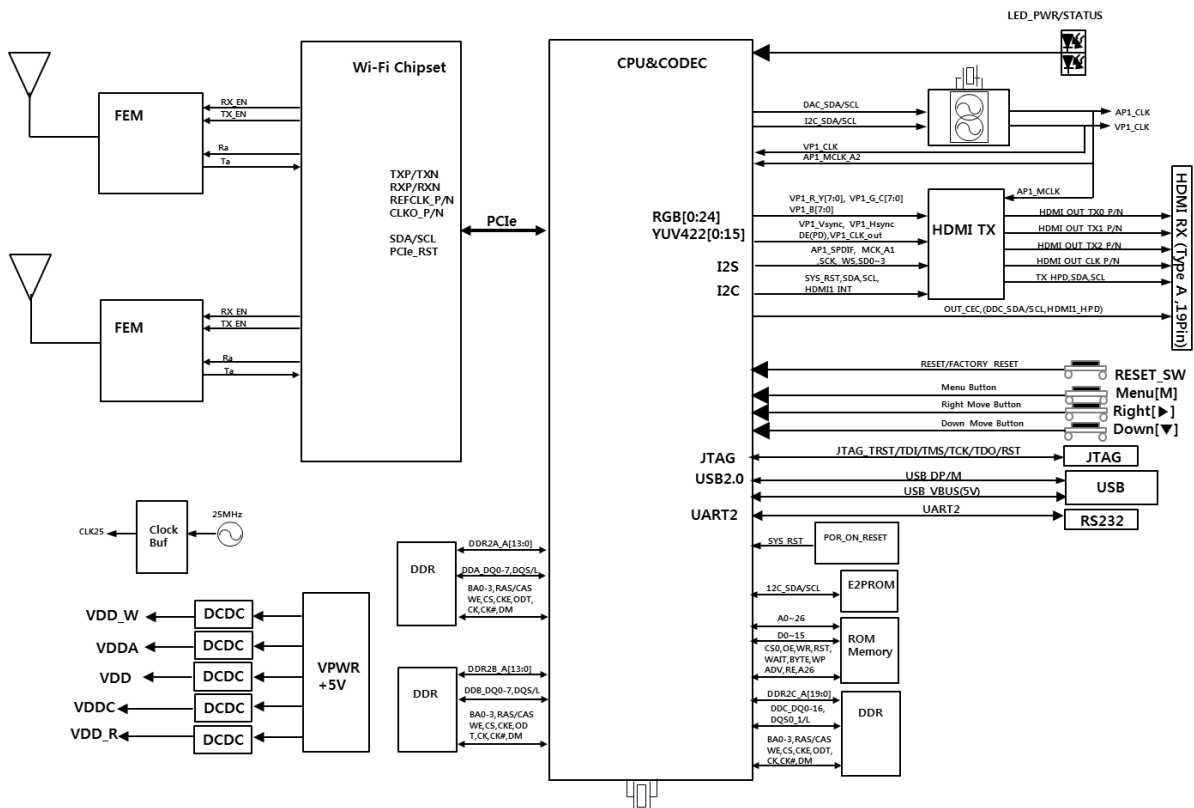



## 7. Drawing

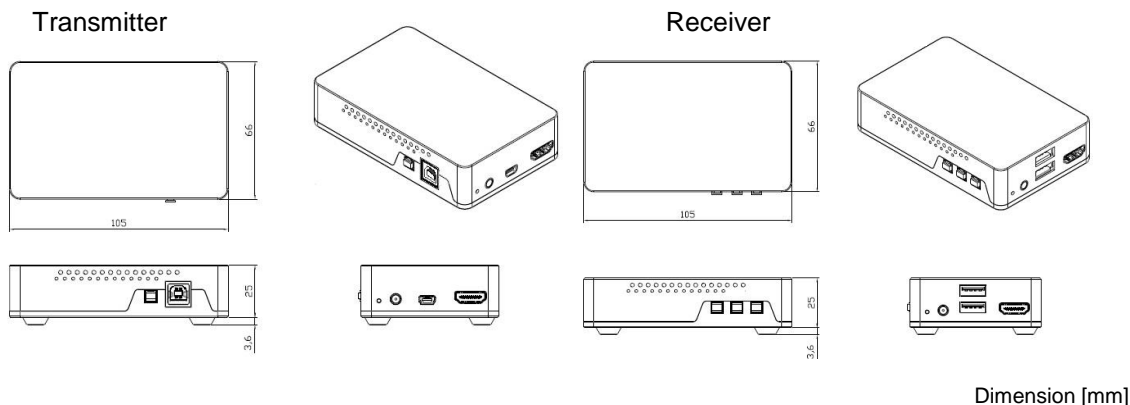

## 8. Troubleshooting

Problem	Solution	Causes
No video on the display	<ul style="list-style-type: none"> <li>- Wait several seconds for the system booting. After the power is applied, Power status and Wireless status LED will turn on (Blue).</li> <li>- Check the connection of all cables.</li> <li>- Reset the power of all Tx and Rx's by re-plugging the power adaptor.</li> </ul>	Cables are connected incorrectly.
"Wi-Fi time out" or "Off" message on the display	<ul style="list-style-type: none"> <li>- Check the environment of your room and re-plug the power adaptor.</li> <li>- Check the distance between Rx and Tx and avoid a metallic obstacle.</li> <li>- Check and retry connections in the GUI connectivity menu.</li> </ul>	A failure of wireless network and/or necessity of pairing between Tx and Rx.
Video quality: - Freezing or collapse - Mosaic pattern - Jitter	<ul style="list-style-type: none"> <li>- Check network connectivity.</li> <li>- Check the distance between Rx and Tx, and avoid a metallic obstacle.</li> <li>- Change the position of antennas.</li> <li>- Change wireless channel. Follow instructions in this user manual (Step 4-2).</li> </ul>	Network connectivity issues Wireless channel interference
After changing source resolution, no video on display	<ul style="list-style-type: none"> <li>- Wait several seconds for the EDID negotiation.</li> </ul>	It takes several seconds for the EDID negotiation between display and source.
Abnormal operation occurs in playing audio/video or USB KVM.	<ul style="list-style-type: none"> <li>- Reset the power of all Tx's and Rx's again by re-plugging the power adaptor.</li> </ul>	
After changing input source, the video clip does not play.	<ul style="list-style-type: none"> <li>- Execute window media player again.</li> </ul>	