

# **Quick Assembly for Rack Mount Slider**

**V. 1.1**

## 1. Package Contents

- Right rail slider x 1
- Left rail slider x 1
- Nut M6 x 6
- Screw M6 x 8
- Fixing stud x 4

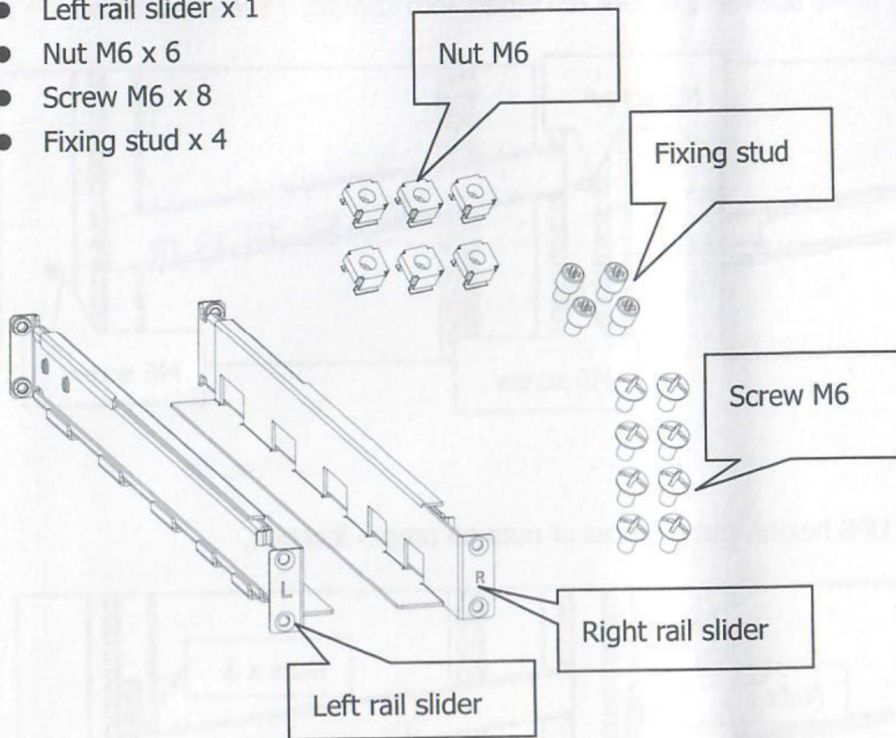

## 2. Assembly Steps

**Step 1:** Insert 4 pieces of fixing nuts into the following locations of rail sliders. Be sure fix them firmly. Then, pull apart two ends of rail sliders and place them in a chassis. Be sure the pulling distance meets the depth of rack chassis and place fixing studs to the corresponding holes on supporting columns. For example, if depth of rack chassis is 700mm, please pull the length of rail sliders is 700mm.

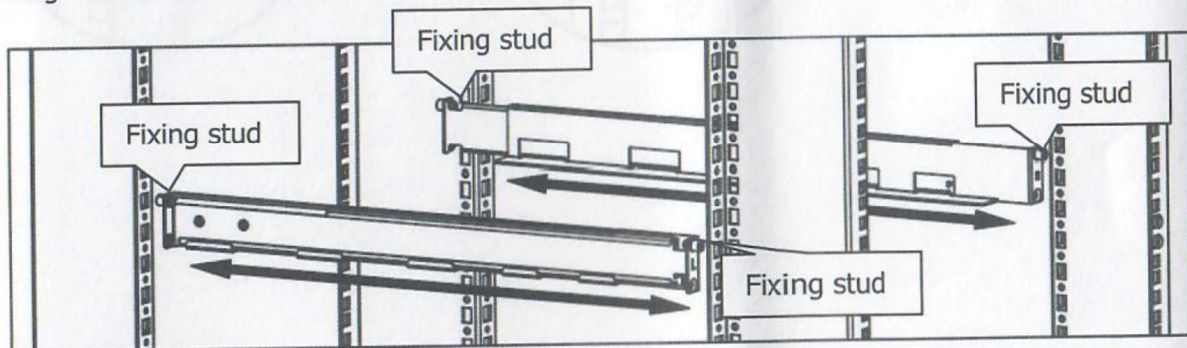

**Step 2:** Use 4 pieces of M6 screws to mount rail sliders into chassis. See chart below:

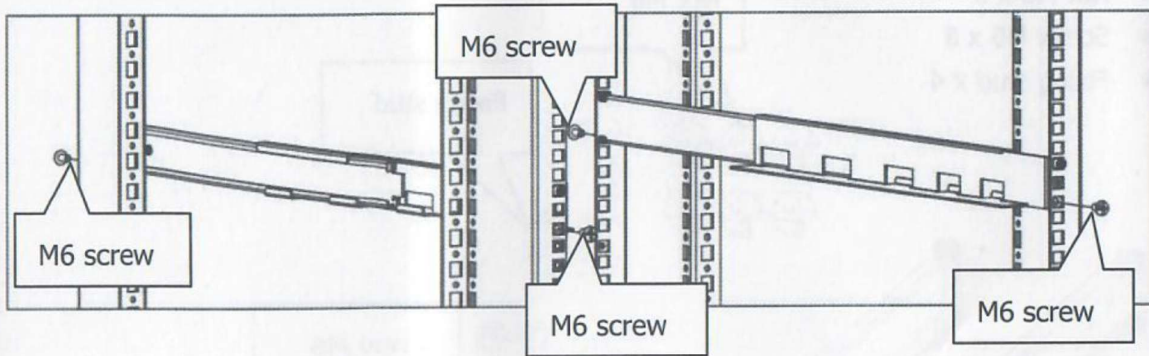

**Step 3:** According to UPS height, put 6 pieces of nuts on proper location.

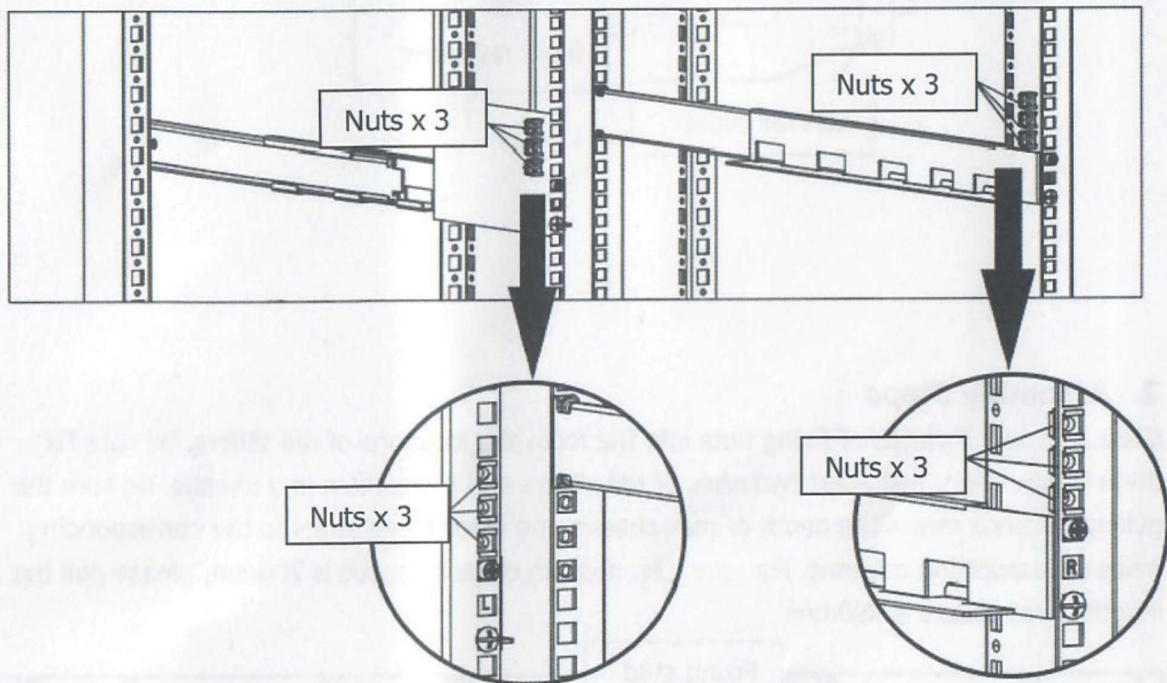

**Step 4:** Put UPS with assembled ears on the rail support.

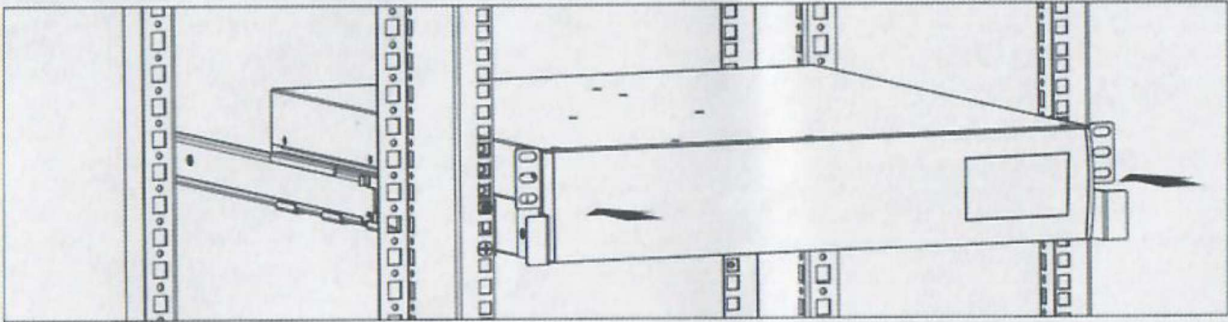

**Step 5:** Fix the UPS in position with 4 screws.

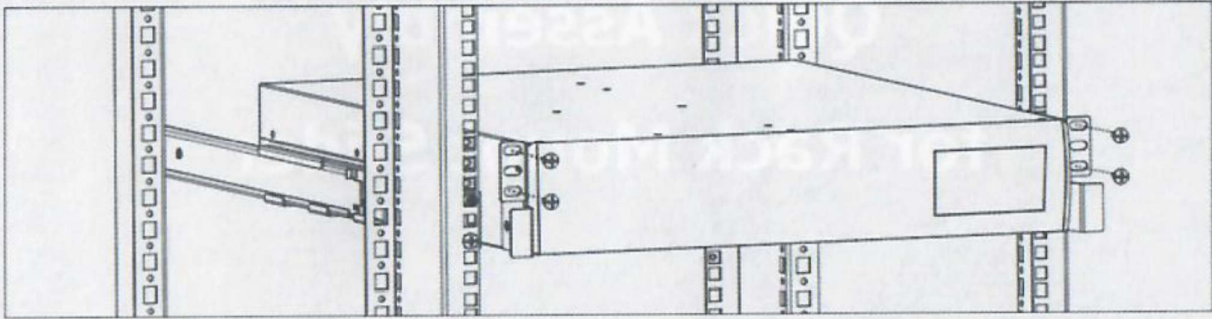

**Step 6:** Assembly complete.

