

Best.nr: 20100851

5 Port PoE Switch

Combo 56V+24V

USER'S MANUAL

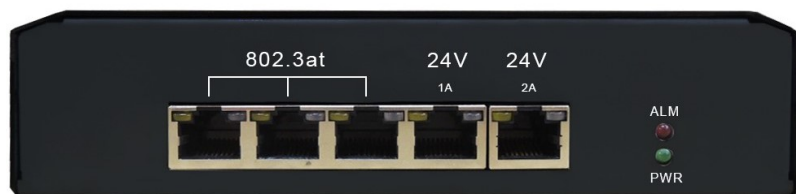

1. General Information

The 24VDC input PoE (Power Over Ethernet) Switch provide five 10M/100M/1000M TX ports, three with standard 802.3at PSE function, plus one with 24V 24W passive PoE and one with 24V 48W 4 pairs passive PoE, the model deliver both of Ethernet data and DC power through the traditional UTP or STP cable.

2. Hardware Description

*LED Indicator

There are 12 LEDs on the PoE switch to indicate the status of power and signal. The following section describes the functions of each LED indicator.

Front panel detail

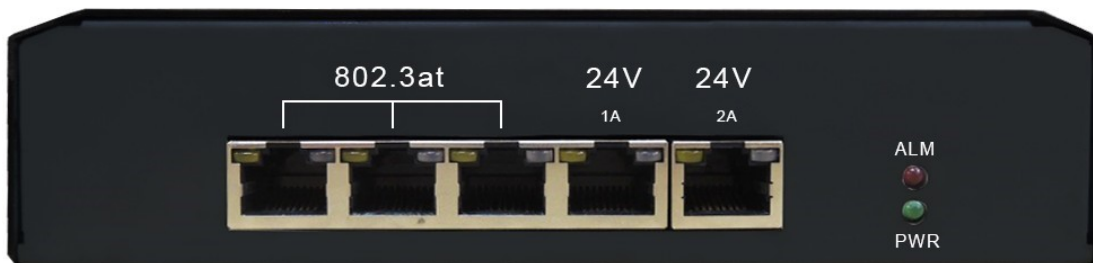

*POWER LED

LED	STATUS	Description
Power	Green	LED ON when DC power input has valid power supplied.
	Red	LED ON when the following warning happens. *24V power output under voltage ($V_{out} < 16V$) *24V power output over voltage ($V_{out} > 33V$) *24V PoE over current (1.25A/P4 or 2.5A/P5)
	Off	No power supplied.

***SWITCH LED (the right indicator on RJ45)**

LED	STATUS	Description
P1~P5 Link/Act	Green	A network device is detected (1000Mbps), but no communication activity is detected.
	Green Blinking	This port is transmitting to, or receiving package from another device at 1000Mbps.
	Yellow	A network device is detected (10Mbps or 100Mbps), but no communication activity is detected.
	Yellow Blinking	This port is transmitting to, or receiving package from another device at 10Mbps or 100Mbps.
	Off	No device is detected.

***PoE LED (the left indicator on RJ45)**

P1~P3 802.3at PoE	Yellow	A valid Powered Device (PD) is detected and delivering power on this port.
	Off	No PD is detected on this port.
P4 24V PoE	Yellow	24V power output (Alternative B)
	Off	No power output
P5 24V PoE 4 pairs	Yellow	24V power output (Alternative A+B)
	Off	No power output

***Power wiring**

For PoE operation, make sure your power supply may offer at least 200W for PoE port.
Total power of PoE is 35W x3 (802.3at), 24W x1 (24V/1A) and 48W x1 (24V/2A).

Powered on rear terminal, please make sure the input current don't over 15Amp (internal fuse specification)

Please note green connector is capable of 12A max. If more current is required, use 4 pin DIN connector for up to 15A.

Ports 1~4 will deliver DC power over the Ethernet cable as Mode B detailed as below:

- * Data pair A on line 1 and 2
- * Data pair B on line 3 and 6
- * Data pair C plus V+ on line 4 and 5
- * Data pair D plus V- on line 7 and 8

Ports 5 will deliver DC 24V power over the Ethernet cable as Mode A+B detailed as below:

- * Data pair A plus V+ on line 1 and 2
- * Data pair B plus V- on line 3 and 6
- * Data pair C plus V+ on line 4 and 5
- * Data pair D plus V- on line 7 and 8

The terminal block on rear panel should be wiring as:

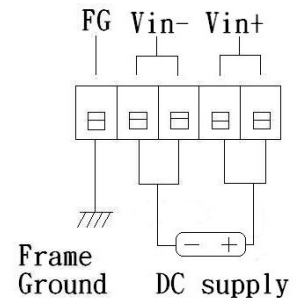

Model	Input Voltage (REAR)	Output Voltage (Port 1~3)	Output voltage (Port4~5)	802.3af/at	Isolated
20100851	18-32VDC	56VDC (regulated)	24VDC (regulated)	Yes (port 1~3)	No

*Ethernet Port Wiring

The PoE switch supports one RJ-45 uplink (port 1 with 802.3at PSE) and four RJ-45 ports (port 2~3 with 802.3at PSE, and port4-5 with 24V passive PSE) with automatic MDI/MDI-X crossover, auto-sense the speed and duplex for 10Base-T, 100Base-TX or 1000Base-T connection. Automatic

MDI/MDI-X crossover allows you to connect to other devices (switches, hubs, or workstations etc.), without regard to using straight-through or crossover cabling.

Port 1 to 4 provides Power over Ethernet function that delivers DC power through the spare pairs (pin 4, 5 and 7, 8) to the PD. Port 5 use all 4 pairs.

The following tables describe the wiring diagram of straight-through and crossover cabling. That crossover cables simply cross-connect the transmit lines at each end to the receive lines at the opposite end.

Straight-through Cabling	
Pin 1	Pin 1
Pin 2	Pin 2
Pin 3	Pin 3
Pin 6	Pin 6
Pin 4	Pin 4
Pin 5	Pin 5
Pin 7	Pin 7
Pin 8	Pin 8

Cross-over Cabling	
Pin 1	Pin 3
Pin 2	Pin 6
Pin 3	Pin 1
Pin 6	Pin 2
Pin 4	Pin 7
Pin 5	Pin 8
Pin 7	Pin 4
Pin 8	Pin 8

Connect an Ethernet cable into any switch port and connect the other side to your attached device.

The Link/Act LED (green or yellow) will light up when the cable is correctly connected. Refer to the **LED Indicator** section for descriptions of each LED indicator.

If a port LED is off, go back and check for connectivity problems between that port and the network device connected.

The maximum cable length for 10/100/1000BaseT with Cat 5 twisted pair cables is typically 100m (328 ft).

*PD Device Wiring

Port 1 to 5 provide PoE inject function to power up the powered device use the straight-through or cross-over Ethernet cable.

The PoE switch follows the IEEE802.3af/at Alternative B mode connector assignment. The following table shows pin assignment of alternative A and B for the Power Source Equipment.

Conductor	Alternative A (MDI-X)	Alternative A (MDI)	Alternative B (All)
1	Negative Vport	Positive Vport	
2	Negative Vport	Positive Vport	
3	Positive Vport	Negative port	
4			Positive Vport
5			Positive Vport
6	Positive Vport	Negative Vport	
7			Negative Vport
8			Negative Vport

Be sure the twisted pair cable is bound with the standard RJ-45 pin, especially the pin 1, 2, 3 and 6. If the RJ-45 is bound with the wrong pin number, PoE switch will not recognize the PD and won't deliver DC power to PD. The yellow PoE LED will light up when the cable is correctly connected. Refer to the **LED Indicator** section for descriptions of each LED indicator. If a port LED is off, go back and check for connectivity problems between that port and the network device connected.

3. Technical Specifications

Standards	IEEE802.3/IEEE802.3u standards/IEEE802.3ab (10 base-T/100base-TX/1000base-T)
Ports	5 ports with PoE output , support auto-crossover & auto-polarity
Transmission speed	1000Mbps (1000base-T).100 Mbps (100base-TX), 10 Mbps(10base-T) Auto-negotiation
Switch technology	store-and-forward
Protocols	CSMA/CD
Flow control	IEEE802.3x (full-duplex), back pressure (half-duplex)
Data transmission rate	1488000pps for1000base-T, 148800pps for 100base-T, 14880pps for 10base-T
Address table	1K MAC address table, self-learning
Connect	RJ-45
PoE port	Port 1-3, 56V PSE auto power management Port 4, 24V 24W passive PoE Pin assignment: *B mode: data pair C plus V+(4,5), data pair D plus V-(7,8) Port 5, 24V 48W Passive PoE Pin assignment: *A+B mode: data pair A plus V+(1,2), data pair B plus V-(3,6) data pair C plus V+(4,5), data pair D plus V-(7,8)
Maximum PoE power	Port 1-3: IEEE802.3at – 35W (802.3at 2 event classification) Port 4: 24V 1A (24W) Port 5: 24V 2A (48W) 4 pairs

PSE disconnect mode	DC disconnect
PoE auto detection	IEEE802.3af & IEEE802.3at (2 event classification signaling)
PoE protection	Over-temperature, over-current, over/under voltage
LEDs	<p>*Link/Activity (Green ON/ Green Blinking @1000Mbps, Yellow/Yellow Blinking @10M/100Mbps)</p> <p>*PoE (Yellow): port 1-3 ON - PD detect, port 4-5 ON – 24V output</p> <p>*POWER: Green-normal, Red-24V passive PSE alarm</p>
Power input	18V~32VDC input @ rear terminal
Power consumption	<5W without PD loading
Power efficiency	85% at full load (@24V typical)
Operating temperature	-40°C ~ +70°C
Operation humidity	90% relative humidity, non-condensing with conformal coating
Storage temperature	-40°C ~ +85°C
Dimension	40mm(H)x180mm(W)x150mm(D) DIN rail mount available

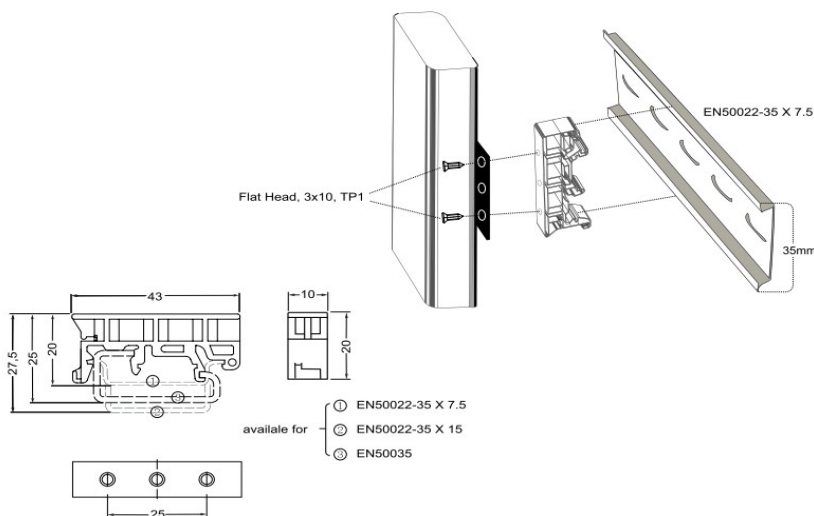

RATING TEMPERATURE LIMITS AND OUTPUT POWER RANGE

