



User Guide

Direktronik Connect Omanagerad 4xPoE + 2xSFP

This document applies to 20117398 Switch. Unless otherwise specified, 20117398 is used as an example in the product diagram.

Packing List

When using the Switch for the first time, carefully open the packing box. The packing box should contain the following items:

- PoE Switch *1
- User Guide *1
- Phoenix Terminal *2

 **Note:** Precision devices are built in the device, please handle them carefully to avoid violent vibration, which may affect the performance of the device. If you find that the equipment is damaged or any parts are lost in the process of transportation, please inform us, we will give you a proper solution as soon as possible.

Statement

Product specifications and information mentioned in this manual are for reference only and are subject to change without prior notice. Unless otherwise agreed, this manual is for use only and does not constitute any form of warranty.

Convention

The product pictures in this document are for illustration only. The number and positions of ports depend on actual models. This document helps you correctly use the Switch. It describes the performance characteristics of the Switch and describes how to install the Switch. Read this manual carefully before operating the Switch.

Directory

<u>Chapter 1 Introduction To The User Guide.....</u>	<u>3</u>
1. <u>Use.....</u>	<u>3</u>
2. <u>User Manual Overview.....</u>	<u>3</u>
<u>Chapter 2 Product Introduction</u>	<u>4</u>
1. <u>Product Overview</u>	<u>4</u>
2. <u>Product Features.....</u>	<u>4</u>
3. <u>Product Advantage.....</u>	<u>5</u>
<u>Chapter 3 Product Appearance Description.....</u>	<u>6</u>
1. <u>Front Panel.....</u>	<u>6</u>
2. <u>Dip Switch Indicator Status Description.....</u>	<u>6</u>
3. <u>LED Indicator.....</u>	<u>7</u>
4. <u>Side Plate.....</u>	<u>8</u>
<u>Chapter 4 Installation Guide.....</u>	<u>9</u>
1. <u>Installation Precautions.....</u>	<u>9</u>
2. <u>Installation Environment.....</u>	<u>9</u>
3. <u>Installation.....</u>	<u>10</u>
<u>Appendix: Technical Specifications.....</u>	<u>13</u>

Chapter 1 Introduction To The User Guide

Thank you for purchasing our 4-Port Gigabit+2G SFP industrial grade Unmanaged PoE Switch! The device adopts no fan, low power consumption design, has the advantages of easy to use, compact and beautiful, simple installation. The product is designed to meet Ethernet standards, with lightning protection, static protection mechanism, operating temperature range of -40°C to 75°C, stable performance, safety and reliability, can be widely used in intelligent transportation, telecommunications, security, financial securities, customs and other broadband data transmission fields.

1. Use

This document aims to familiarized users with and correctly use Direktronik Connect Omanagerad 4xPoE + 2xSFP Switch.

2. User Manual Overview

Chapter 1: Introduction To The User Guide.

Chapter 2: Product Introduction.

Chapter 3: Product Appearance Description.

Chapter 4: Installation Guide.

Appendix: Technical Specifications.

Chapter 2 Product Introduction

2.1 Product Overview

20117398 is an industrial Unmanaged PoE Switch independently developed by our company. 4*10/100/1000Mbps adaptive RJ45 ports and 2*1000Mbps SFP optical module slots are provided. Each RJ45 port supports MDI/MDIX automatic flip and wire-speed forwarding. Ports 1-4 support PoE power supply. PoE ports automatically detect PD devices and supply power to PD devices that comply with IEEE 802.3af/at standards. Each port can provide up to 30W power.

2.2 Product Features

- Operating temperature: -40°C ~ 75 °C;
- Low power consumption fanless, high energy aluminum alloy roof heat conduction groove shell design;
- DIN-Rail type installation;
- Industrial grade components;
- Support IEEE 802.3af/at standards;
- Single port output power up to 30W;
- IEEE 802.3x full-duplex flow control and Backpressure half-duplex flow control;
- Automatic detection of PD devices;
- Port power priority is supported to ensure continuous power supply for key nodes on the network;
- Supports CCTV and VLAN functions;
- Support for the PD-ALIVE function;
- Panel indicators monitor working status and assist in fault analysis;
- Perfect security mechanism.

2.3 Product Advantage

➤ **-40°C ~ 75 °C operating temperature design**

-40°C~75°C operating temperature design, selected industrial components, the use of natural heat dissipation, to ensure that the Switch can achieve long-term stable operation within the temperature range, to meet all kinds of use environment.

➤ **High energy aluminum alloy roof heat conduction groove shell design** Body size

110*90*46mm, compact and light, full aluminum alloy high energy roof heat conduction groove shell design, better heat dissipation effect.

➤ **DIN-Rail installation, simple and flexible**

DIN-Rail installation design, easy and quick installation, so that users reduce unnecessary installation time, save time cost.

➤ **Select industrial grade components**

Chemical nickel gold PCB board, with high corrosion resistance, oxidation resistance. Select high specification capacitor, greatly improve the service life of products.

➤ **Supports power supply priorities**

The device supports port power supply priorities to ensure continuous power supply for key nodes on the network.

➤ **Supports relay alarm function**

Support system startup abnormal and power alarm function, if the system startup or input power abnormal can be timely output alarm signal.

➤ **Supports PD-ALIVE function**

PoE ports support automatic PD monitoring and port data detection. After the PoE port is powered on, the device starts to detect if the port is transmitting data. If the port is not transmitting data and lasts longer than a specific time, the PoE will automatically power down and then power up again.

➤ **Supports VLAN function**

VLAN isolation mode divides ports 1~4 and ports 5/6 of the switch into a separate VLAN. Ports 1~4 can only communicate with 5/6. Ports 1~4 cannot communicate with each other to ensure the security of the network. In this mode, please connect port 5/6 to the central switching device.

➤ **Supports CCTV function**

The transmission rate of the port in this mode is reduced to 10Mbps and the transmission distance is extended to 250m, which can solve the problem of long-distance transmission in network monitoring projects and can replace optical fibers and network extenders, solving the problem of difficult ultra-remote power extraction and reducing engineering wiring costs. To ensure the stability and distance of PoE power transmission, always use 8-core all-copper 0.5 or above national standard cables.

Chapter 3 Product Appearance Description

3.1 Front Panel

The front panel consists of 4*10/100/1000Mbps adaptive RJ45 ports, 2*1000Mbps SFP slots and related indicators, as shown in the following figure:

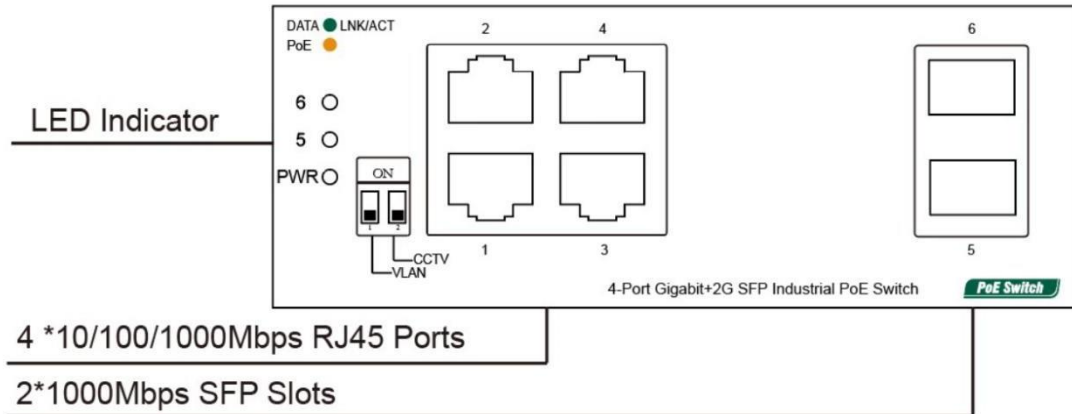

Figure 3-1 Front panel of 20117398

20117398 Port description:

➤ 10/100/1000Mbps RJ45 Ports

Supports 10Mbps, 100Mbps, or 1000Mbps rate adaptation, auto-MDI /MDIX, and each port has a corresponding indicator, that is, port indicators 1-4 as shown on the panel in the figure above.

➤ 1000Mbps SFP Slots

SFP slots are independent SFP slots on the right of the panel. Each port has a corresponding indicator, that is, the indicator 5-6 on the panel in the figure above.

3.2 Dip Switch Indicator Status Description

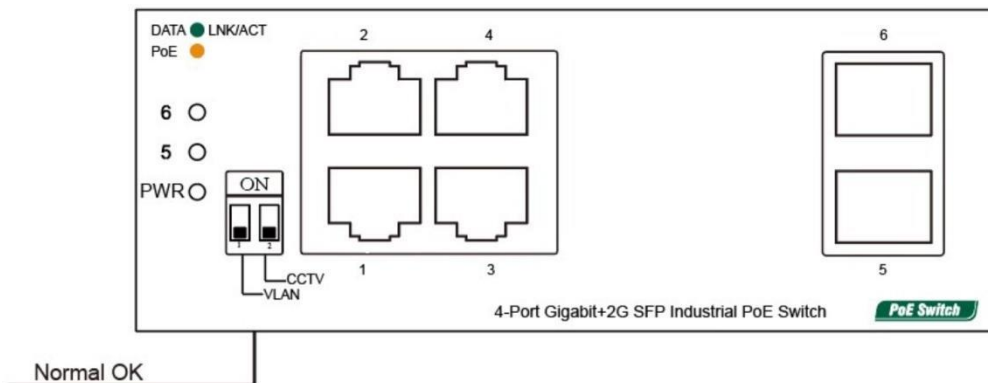

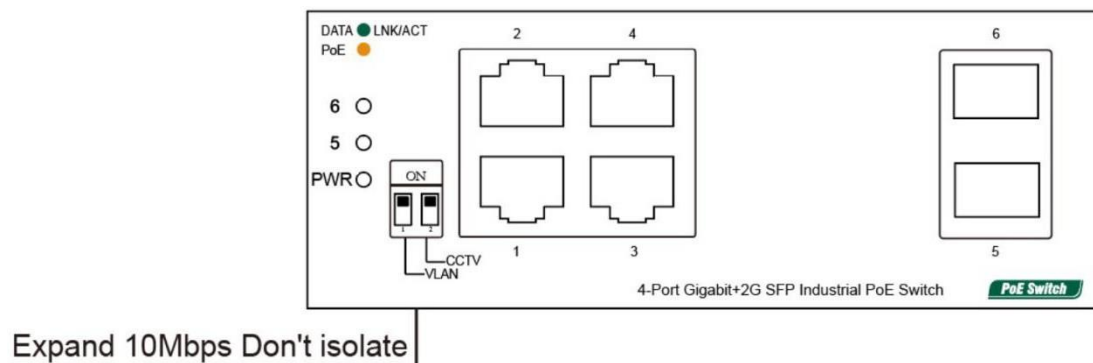
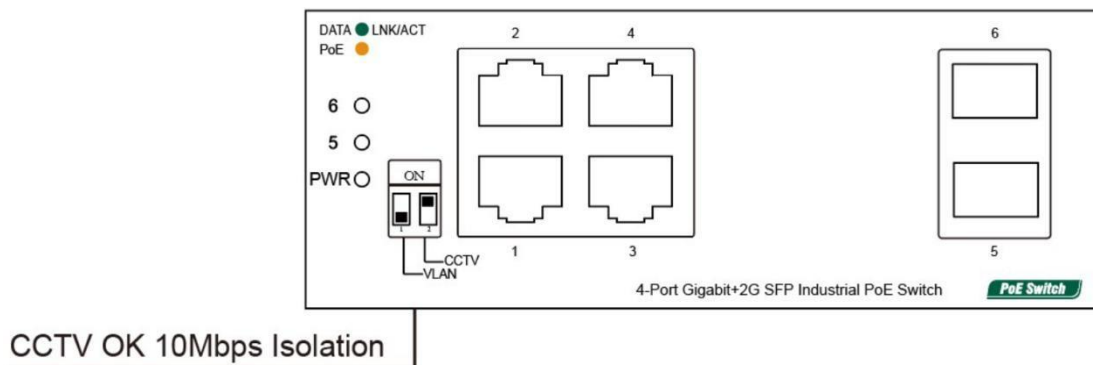
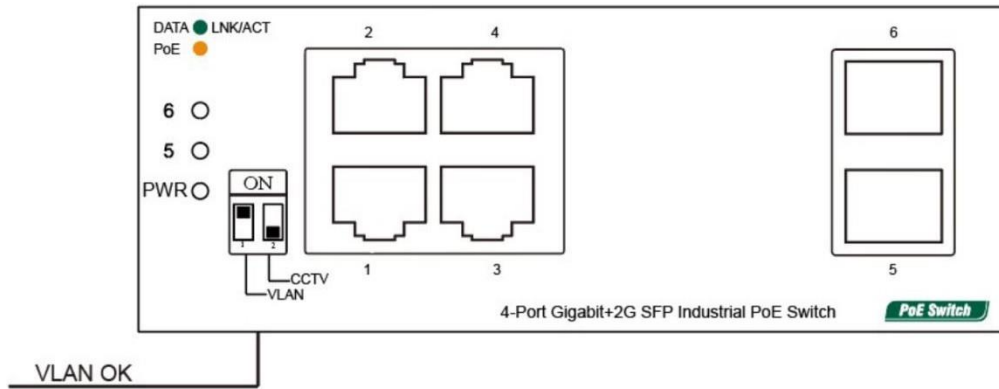

3.3 LED Indicator

The LED indicators of the Switch are shown in the following table. Users can monitor the work and running status of the Switch conveniently and quickly through the following indicators:

LED	Color	Function
PWR	Green	Off: No Power supply. Light: Indicates the Switch has power.
DATA	Green	Off: No device is connected to the corresponding port. Light: Indicates the link through that port is successfully established at 10/100/1000Mbps. Blink: Indicates that the Switch is actively sending or receiving data over that port.
PoE	Orange	Off: No PoE powered device (PD) connected. Light: There is a PoE PD connected to be port, which supply power successfully. Blink: Indicates port abnormal PoE supply.

3.4 Side Plate

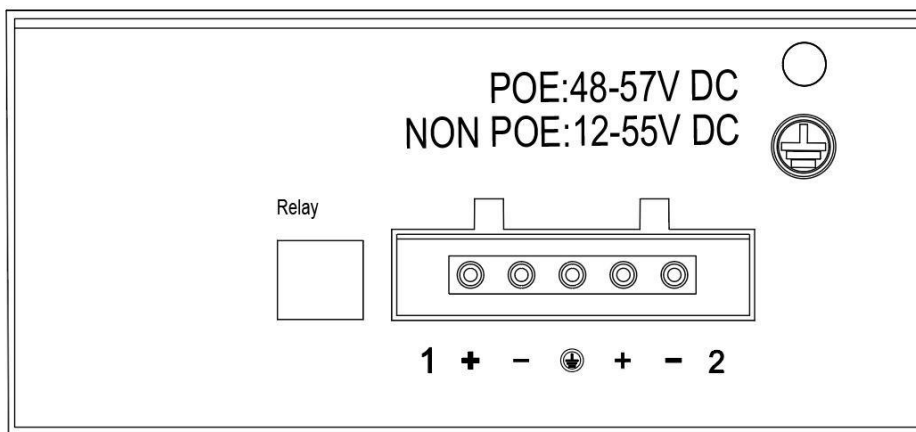

Figure 3-2 20117398 Switch side panel

The side panel of the Switch provides 5-position industrial wiring terminals and power input DC: The standard voltage ranges from 48V to 57V, and the input voltage of 2 PWR1 and PWR2 power supplies ranges from 48V to 57V. The DC power input of the Switch is redundant. The PWR1 and PWR2 power supplies can be used individually or connected to 2 independent DC power supply systems. When any power supply system fails, the device can run normally without interruption, which improves the reliability of network operation.

Relay port : Alarm port, support machine abnormal alarm function. This interface needs to be connected to an external alarm device. When the machine starts abnormally or when the power is on, the internal relay will close and output the alarm signal in time, which has the function of automatic alarm, safety protection and isolation conversion in the circuit.

Chapter 4 Installation Guide

This chapter helps users correctly install and safely use Switches.

1. Installation Precautions



Precautions: To avoid equipment damage and personal injury, observe the following precautions:

- The Switch room should be dry and ventilated, free from corrosive gases and strong electromagnetic interference;
- The humidity of the switch room should be 5% to 95%. If possible, install corresponding facilities ;
- The grounding of the Switch shall comply with the grounding requirements described in this manual, and shall be separately and well grounded;
- Keep a proper distance between the Switch and other devices. Do not stack other devices with the Switch.
- The connection cable between the Switch and the distribution frame should be standardized and reasonable, and the distribution frame (box) jumper wire should be concise and clear to prevent the phenomenon of parallel lines and wires;
- To reduce the risk of electric shock, do not open the shell of the Switch when it is working. Do not open the shell of the Switch even when it is not powered on.



Safety Tips:

- Ensure that the PGND cable of the power socket is properly grounded.
- Ensure sufficient space for heat dissipation and ventilation of the Switch. Do not place heavy objects on the Switch.

4.2 Installation Environment

Before installation, make sure that the proper working environment is available, including power requirements, adequate space, proximity to other equipment to be connected, and other equipment in place. Please confirm the following installation requirements:

- Ensure the stability of the workbench and good grounding;
- Check whether cables and connectors required for installation are in place (less

than 100m).

- Power supply: 48V to 57V DC power supply ;
- Environment: operating temperature: -40°C to 75 °C relative humidity: 5% to 95%.

4.3 Installation

DIN-Rail Installation

The 45mm standard DIN-Rail installation is very convenient for most industrial applications. The installation steps are as follows:

- Check whether the installation accessories of DIN-Rail guide tools are available (installation accessories are provided for this product);
- Check whether DIN-Rail is firmly fixed, whether there is a suitable place to install the product;
- Clamp the lower part of the DIN-Rail connecting seat of the product accessories into the DIN-Rail (lower part with spring support), and then clamp the upper part of the connecting seat into the DIN-Rail (lower part clamp a little, slightly force to keep the balance of the equipment stuck into the upper part).

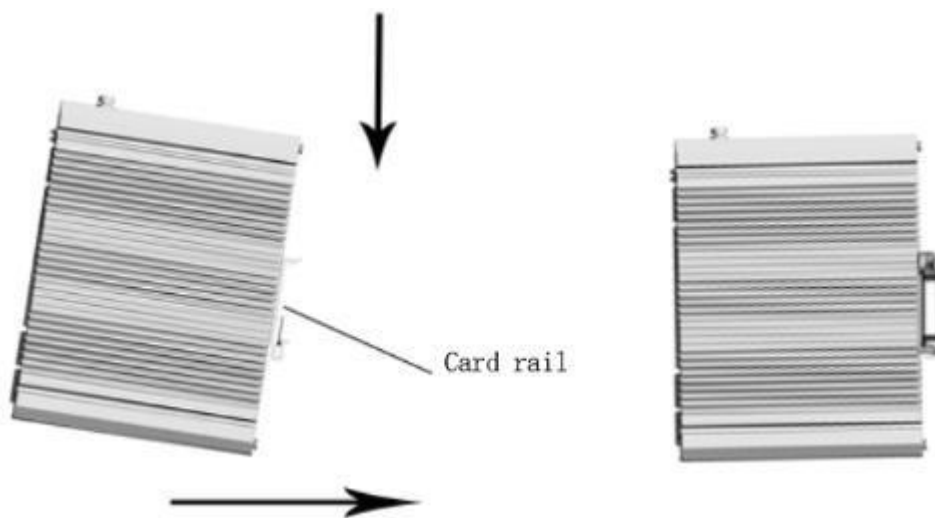

Figure 4-1 Schematic diagram of industrial machine guide rail installation



Note: Aluminum alloy DIN-Rail hooks have been fixed to the rear panel of the Switch.

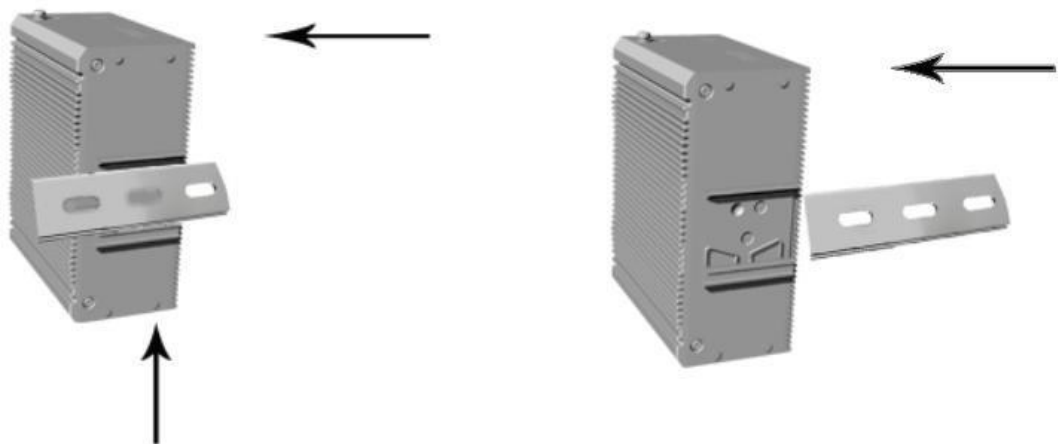

Figure 4-2 Schematic diagram of industrial machine guide rail disassembly



Power on

- Power on: First insert the power terminal of the power cable into the power port of the device, then plug in the power plug and power on. After the Switch is started, the Switch automatically initializes. If all port indicators are on and then off, the system is successfully reset, and the power LED indicator is always on.
- Power off operation: Unplug the power plug first, and then remove the wiring part of the terminal. Please pay attention to the above operation sequence.

Wall mounted installation

The following describes how to install a Switch on the wall:

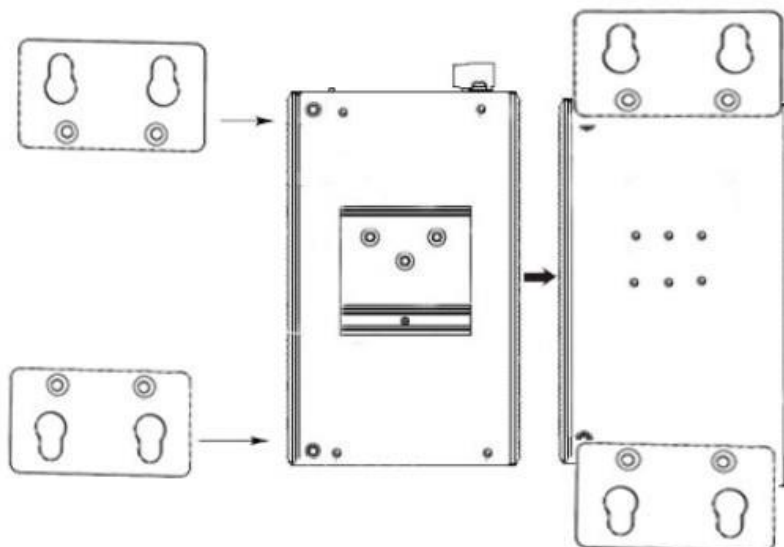

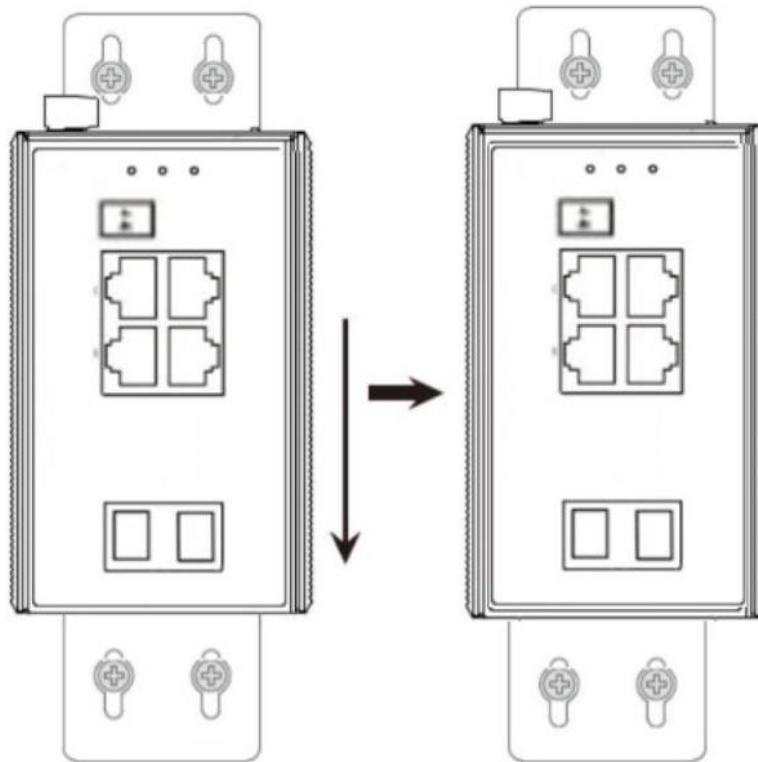

Schematic diagram of wall mounted installation of industrial machine

- Remove the DIN-Rail mounting plate on the rear board of the Switch;
- Install the wall mounting board on the Switch as shown below.
- Four wall screws are required to mount the Switch on the wall, as shown in the figure above.
- When fixing the screws to the wall, do not screw the screws into the wall completely. Leave a space of about 2 mm for sliding the wall panel between the wall and the screws.
- After securing the screws to the wall, place the 4 screw heads through most of the keyhole, then place the Switch vertically and tighten the screws to increase stability.

Appendix: Technical Specifications

Model	Direktronik Connect Omanagerad 4xPoE + 2xSFP
Standard	IEEE 802.3, IEEE 802.3u, IEEE 802.3ab, IEEE 802.3z, IEEE 802.3x, IEEE802.3af, IEEE802.3at
Network Media(Cable)	10BASE-T: UTP category 3,4,5 cable (≤100m) 100BASE-TX: UTP category 5, 5e cable (≤100m) 1000BASE-T: UTP category 5e, 5 cable (≤100m) 1000BASE-X: MMF, SMF
MAC Address Table	4K, Auto-learning, Auto-updating
Jumbo Frame	9216Bytes
Transfer Mode	Store-and-Forward
Packet Buffer	1.5Mbit
Packet Forward Speed	8.93Mpps
Input Power Supply	DC:48-57V
Switching Capacity	12Gbps
Dimensions (L*W*H)	110*90*46mm
Fan	Fanless
PoE Power Budget	120W
PoE Port	Port1~4
PoE Power On RJ45	Mode A 1/2 (-), 3/6 (+)
PoE Output	30W(Max)
Temperature	Operating Temperature: -40°C ~ 75 °C (-40 °F ~167°F) Storage Temperature: -40 °C ~ 80°C (-40 °F ~176°F)
Humidity	Operating Humidity: 5% ~ 95% non-condensing Storage Humidity: 0% ~ 95% non-condensing
MTBF	>100000hours